

SUPER 300 TYPE PILLAR FITTING™ & Insertion Tools

PILLAR

Top market share of
fluorocarbon polymer fittings
for liquid chemical tubes
in the semiconductor
industry



■ Features

High sealing performance

This product applies sealing force not only in the axial direction but also in the radial direction and has a specific sealing structure independent of the driving force of the union nut. It provides stable sealing performance within a wide temperature range for a long period of time.

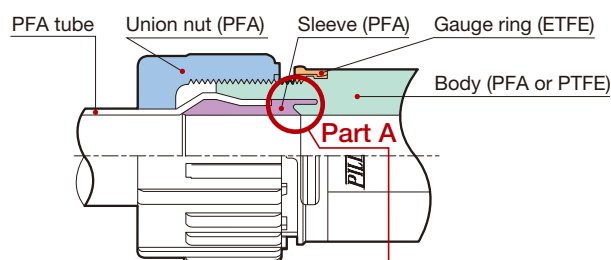

(Except some small-diameter tubes)

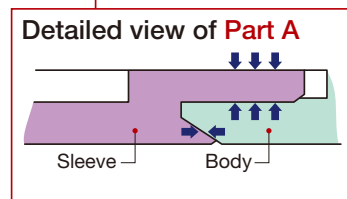

Specifications

- ▶ Maximum operating temperature: 200°C
- ▶ Maximum operating pressure: 0.7 MPaG
- ▶ Applicable fluid: Liquid
- ▶ Applicable tube sizes: $\phi 3$ to $\phi 25$, 1/8" to 1-1/2"
- ▶ Applicable tube materials: PFA and PTFE

■ Operating range

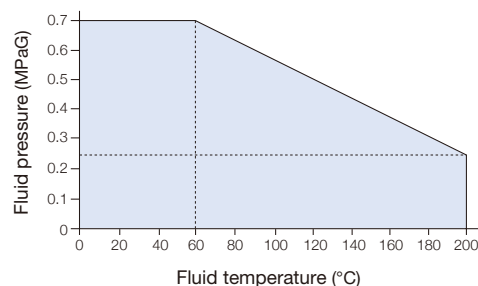

NIPPON PILLAR PACKING CO., LTD.

Simplified tightening control

The adoption of the gauge ring enables union nut tightening control to be implemented through auditory, tactile, and visual senses, which has significantly improved work efficiency. This eliminates variations in installation work such as insufficient tightening or excessive tightening, thereby providing safe and stable performance. (Except some small-diameter tubes)

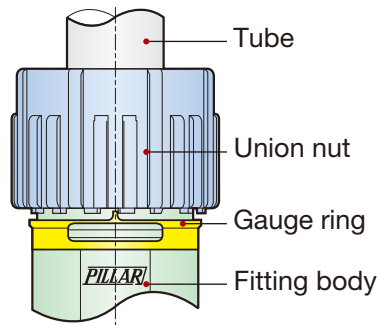
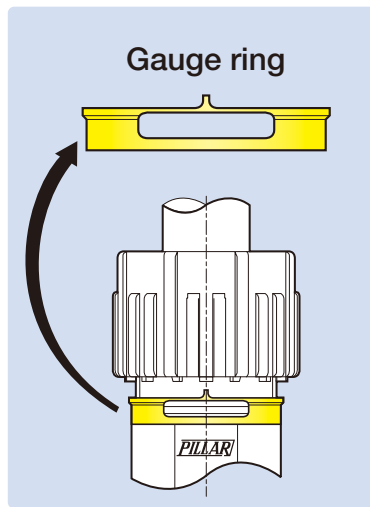

Initial tightening

The union nut comes into contact with the protrusion on the gauge ring and installation completion is notified by sound and tactile response.

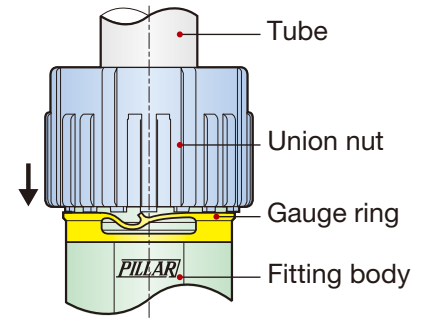

Tightening limit

The union nut comes into contact with the base of the gauge ring and the limit of tightening is notified.

Contributing to downsizing and cost reduction of equipment

Using the space-saving type enables compact equipment design, halving the number of connection positions, thereby reducing workload. In addition to this, we provide a rich array of product types as molded products at low cost and with a short turnaround time.



General type

Space-saving type

Clean and high quality

Integrated production covering materials, molding, processing, assembly, and cleaning is implemented in our own factory cleanrooms compliant with ISO 9001 and ISO 14001.



SUPER 300 TYPE PILLAR FITTING™ & Insertion Tools

Sleeve insertion tool: Room temperature type, for large-diameter tubes

JT-A4

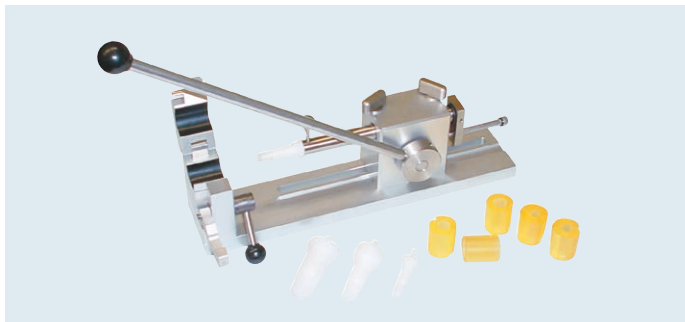

- ▶ Applicable tube sizes: $\phi 10$ to $\phi 25$, 3/8" to 1"
- ▶ Tool body size: 372 (L) \times 62 (W) \times 104 (H) mm
(Maximum arm height: 371 mm)
- ▶ Tool body weight: 2.5 kg

Sleeve insertion tool: For small-diameter tubes

JT-C3



- ▶ Applicable tube sizes: $\phi 3$ to $\phi 10$, 1/8" to 3/8"
- ▶ Tool body size: 296 (L) \times 27 (W) \times 151 (H) mm
- ▶ Tool body weight: 0.58 kg

Sleeve insertion tool: For 1-1/4" and 1-1/2" tubes

PT-E1



- ▶ Applicable tube sizes: 1-1/4" and 1-1/2"
- ▶ Tool body size: 460 (L) \times 105 (W) \times 160 (H) mm
(Maximum arm height: 665 mm)
- ▶ Tool body weight: 8.3 kg

Sleeve insertion tool: Hand held type (for portable use)

JT-SA-KA

* For short tubes, use another tool.



- ▶ Applicable tube sizes: $\phi 3$ to $\phi 25$, 1/8" to 1"
- ▶ Tool body size: 220 (L) \times 53 (W) \times 75 (H) mm
- ▶ Tool body weight: 0.7 kg

Sleeve insertion tools: For heating tubes * For short tubes, use another tool.

Tube flare tool

P-FH

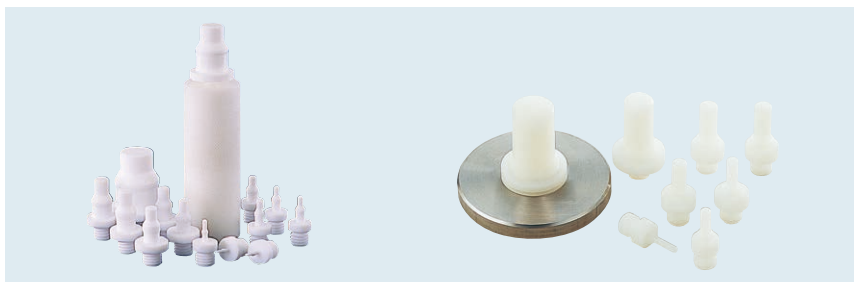

- ▶ Applicable tube sizes: $\phi 3$ to $\phi 25$, 1/8" to 1"

Grip SG-H

- ▶ Material: Resin
- ▶ Size: $\phi 36 \times 100$ (H) mm
- ▶ Weight: 0.14 kg

Sleeve holder

P-SH-H



Base plate SB-H

- ▶ Material: Metal
- ▶ Size: $\phi 80 \times 10$ (H) mm
- ▶ Weight: 0.39 kg

* SG-H and SB-H can be secured with either the tube flare tool or sleeve holder.

Heat gun

JH-H



- ▶ Size: 195 (L) \times 87 (W) \times 160 (H) mm
- ▶ Weight: 1.3 kg
- ▶ Power supply: 100-115 V

Spanner for tightening union nuts

J-SN-SET

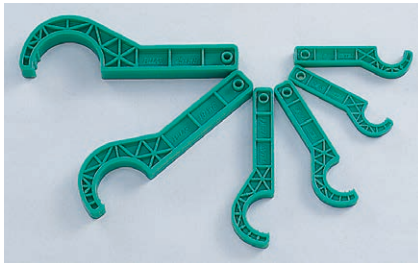

Spanner for use in narrow places



▶ Applicable tube sizes: $\phi 6$ to $\phi 25$, 1/4" to 1"

* A spanner for use in narrow places is also available as an option.

Gap gauge for partly small-diameter tubes
(For $\phi 3$, $\phi 4$, and 1/8" outside diameter tubes)

SSG-SET-P

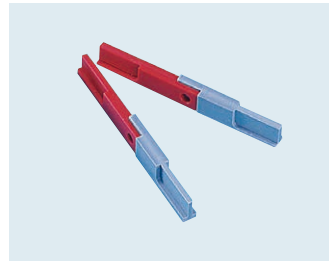

▶ • SSG-3: For $\phi 3$ and 1/8" dia. tubes • SSG-4: For $\phi 4$ tubes

For union nut tightening control for $\phi 3$, $\phi 4$, and 1/8" outside diameter tubes, use this gap gauge to check the gap between the fitting body and the union nut.

Tube cutter

PTC-1



Easy type



▶ Applicable tube sizes: $\phi 3$ to $\phi 25$, 1/8" to 1"

* An easy type with a wide tube fixing portion is also available. However, this is not suitable for cutting short tubes.

Tube cutter

PTC-2



▶ Applicable tube sizes: 1-1/4" and 1-1/2"

List of sleeve insertion tool models

For details on how to use dedicated tools, refer to the latest edition of the Instruction Manual (No. 203-1) for $\phi 3$ to $\phi 25$ or 1/8" to 1" diameter tubes or the Instruction Manual (No. 205-1) for 1-1/4" and 1-1/2" diameter tubes.

Insertion tool body	Room temperature type				For heating tubes		Hand held type (for portable use)			
	JT-A4		JT-C3		SB-H or SG-H		JT-SA-KA			
	Tube holder	Sleeve holder	Tube holder	Sleeve holder	Tube flare tool	Sleeve holder	Tube holder	Sleeve holder	Attachment*2 (for sleeve holder)	
Set product name	JT-A4-SET-P		JT-C3-SET-P		P-FH-SET	P-SH-H-SET	JT-SA-KA-SET-P			
Tube outside diameter	Tube holder	Sleeve holder	Tube holder	Sleeve holder	Tube flare tool	Sleeve holder	Tube holder	Sleeve holder	Attachment*2 (for sleeve holder)	
3 mm	—	—	J-TH-C1	P-SH-CK3	P-FH-3	P-SH-H3	J-TH-SA3-KA	P-SH-SBK3	SA-SB-AT	
4	—	—	J-TH-C1	P-SH-CK4	P-FH-4	P-SH-H4	J-TH-SA4-KA	P-SH-SBK4		
6	—	—	J-TH-C2	P-SHP-CK6 (W2)	P-FH-6	P-SH-H6 (W2)	J-TH-SA6-KA	P-SHP-SBK6 (W2)		
8	—	—	J-TH-C2	P-SHP-CK8	P-FH-8	P-SH-H8	J-TH-SA8-KA	P-SHP-SBK8		
10	J-TH-A10	P-SHP-AK10	*1	—	*1	P-FH-10	P-SH-H10	J-TH-A10	P-SHP-SBK10	Not required
12	J-TH-A12	P-SHP-AK12	—	—	—	P-FH-12	P-SH-H12	J-TH-A12	P-SHP-SBK12	
19	J-TH-A19 (W6)	P-SHP-AK19 (W6)	—	—	—	P-FH-19 (W6)	P-SH-H19 (W6)	J-TH-A19 (W6)	P-SHP-SAK19 (W6)	
25	Not required	P-SHP-AK25 (W8)	—	—	—	P-FH-25 (W8)	P-SH-H25 (W8)	Not required	P-SHP-SAK25 (W8)	
1/8"	—	—	J-TH-C1	P-SH-CKW1	P-FH-W1	P-SH-HW1	J-TH-SAW1-KA	P-SH-SBKW1	SA-SB-AT	
1/4"	—	—	J-TH-C2	P-SHP-CK6 (W2)	P-FH-W2	P-SH-H6 (W2)	J-TH-SAW2-KA	P-SHP-SBK6 (W2)		
3/8"	J-TH-AW3	P-SHP-AKW3	*1	*1	*1	P-FH-W3	P-SH-HW3	J-TH-AW3		P-SHP-SBKW3
1/2"	J-TH-AW4	P-SHP-AKW4	—	—	—	P-FH-W4	P-SH-HW4	J-TH-AW4		P-SHP-SBKW4
3/4"	J-TH-A19 (W6)	P-SHP-AK19 (W6)	—	—	—	P-FH-19 (W6)	P-SH-H19 (W6)	J-TH-A19 (W6)	P-SHP-SAK19 (W6)	Not required
1"	Not required	P-SHP-AK25 (W8)	—	—	—	P-FH-25 (W8)	P-SH-H25 (W8)	Not required	P-SHP-SAK25 (W8)	

Note: JT-A4-SET-P, JT-C3-SET-P, and JT-SA-KA-SET-P contain the insertion tool body.

*1: JT-C3 also allows sleeve insertion for $\phi 10$ or 3/8" diameter tubes. For details, please contact us separately. *2: The attachment is a part for connecting the tool body and sleeve holder.

Insertion tool body	PT-E1		
Tube outside diameter	Tube holder	Sleeve holder	Sleeve holder for short tubes
1-1/4"	P-TH-EW10	P-SH-EKW10	P-SH-EW105
1-1/2"	P-TH-EW12	P-SH-EKW12	P-SH-EW125

PILLAR NIPPON PILLAR PACKING CO., LTD.

Head office/Sales Headquarters
7-1, Shinmachi 1-chome, Nishi-ku, Osaka 550-0013, Japan
Phone: +81-6-7166-8326 Fax: +81-6-7166-8514

Email : sales@pillar.co.jp

<https://www3.pillar.co.jp/en/product/>



Safety precaution

● When using this product, please use correctly and pay sufficient attention to safety.

* Please understand that this catalog may change without prior notice.

* The values shown on this catalog are reference values, not guaranteed values.