

PILLAR

Pillar Cassette Seal[®]



NIPPON PILLAR PACKING CO., LTD.

► Reliability

Thanks to the sleeve integral design, our mechanical seal has a long term stable performance. In addition, springs position contributes in eliminating leakage preventing the deterioration of seal ring operability.

► Adaptability

"Type GABE 5" for high pressure, "type GXKEM" for high concentration slurry and "tandem seal type" are added, centered on "type GAKEM" adopted with knife edge seal.

► Simplicity

The installation of the mechanical seal doesn't require more than 4 steps.

► Changeability

Ideal for replacing from gland packing

Pillar Cassette Seal [®]

Cassette seal cross section
GXKEM

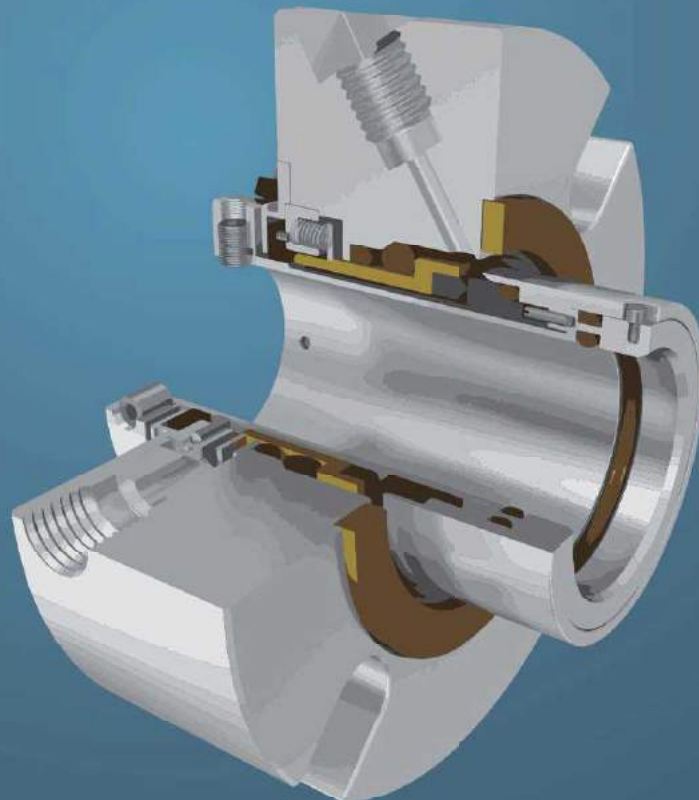

Pillar Cassette Seal Line up

"Pillar Cassette Seal" has many characteristics such as stationary cartridge and easy installation.

Various options are provided so that Pillar Cassette Seal can be applied to a wider range of use.

GAKEM

STANDARD · KNIFE EDGE TYPE

Standard configuration for SiC vs. SiC (seal face material) + knife edge seal.

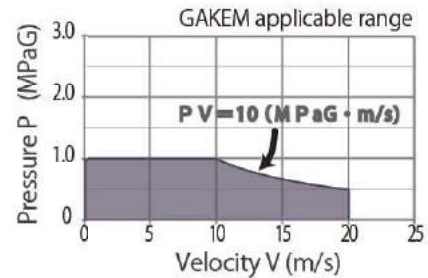
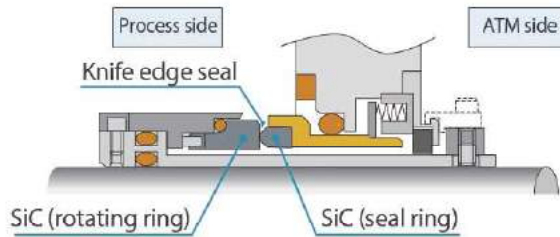

GXKEM

HIGH CONCENTRATION SLURRY COMPATIBLE TYPE

Shielded O-ring minimizes the adverse effect of slurry.

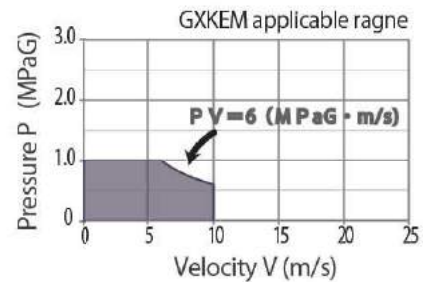
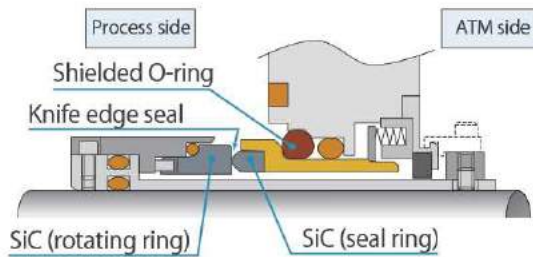

GABE5

HIGH PRESSURE TYPE

With a versatile seal face, combining SiC and Carbon, this type supports fluid pressure up to 2.5MPaG

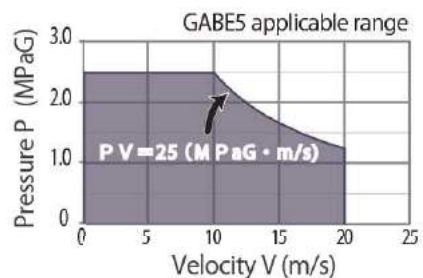
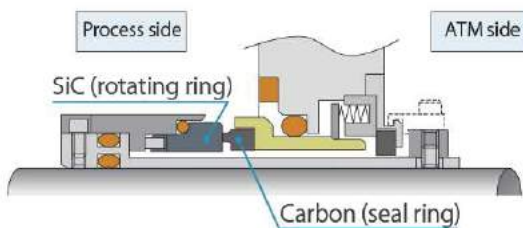

Tandem Seal Option

An atmospheric side secondary seal can be designed integrally with any pillar cassette seal. By tandem seal, it can deal with minimum leakage and scattering of quench liquid.

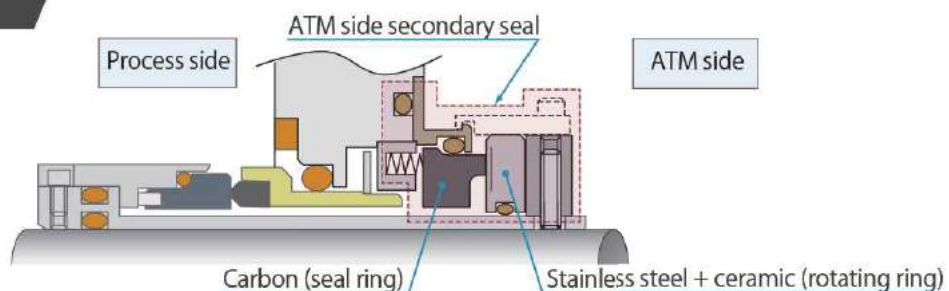

※The figure is in combination with GAKEM.

4 actions installation

"Compact design" which can be applied by bolt on to ISO · DIN standard pumps.
The "4 actions installation" does not require measuring or equipment dimension adjustment which widens the range pumps it can be applied on.

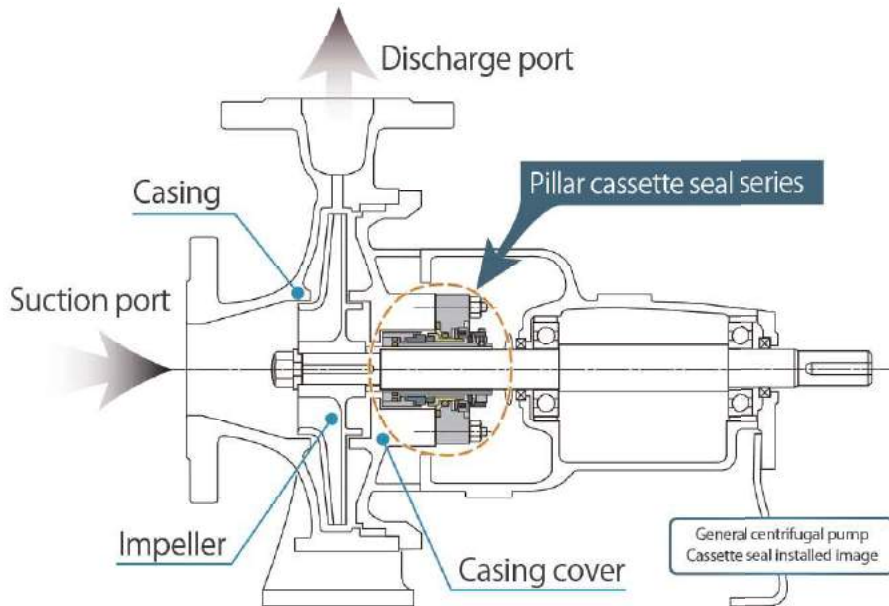

4 ACTIONS INSTALLATION

Action 1

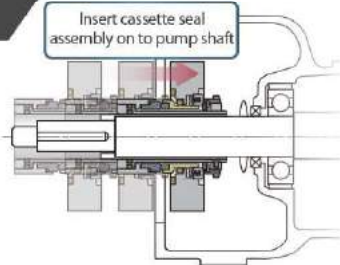

Insert "cassette seal assembly" on to the shaft of the pump from which the casing, impeller and casing cover are removed.

Action 2

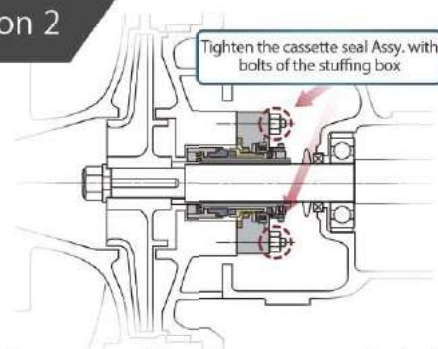

After reassembling the pump main body, fix the "cassette seal assembly" with the stuffing box bolt.

Action 3

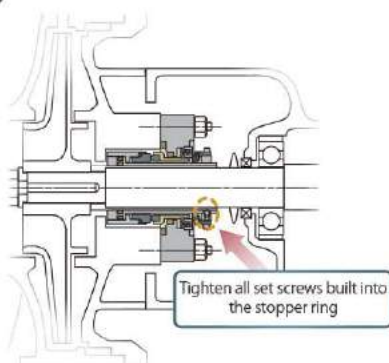

Tighten all of the cassette seal's set screws and secure the seal rotation side part and the pump shaft.

Action 4

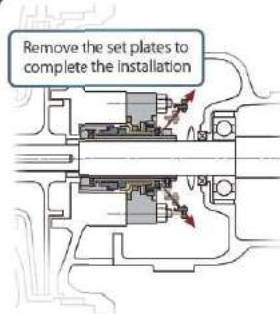



In the state of "Assy.", Remove the "set plates" that had been restricted to the prescribed tightening length, and the installation work of the mechanical seal is completed. (Note) "Set plate" is also necessary for removing cassette seal.

Pillar Seal

"Unique technology of pillar's mechanical seal" has been backed up and improved as a result of years of experience. Inherent technologies are standard loaded in the "cassette seal series". Product's reliability and versatility distinguish them from equivalent products.

KNIFE EDGE TECHNOLOGY

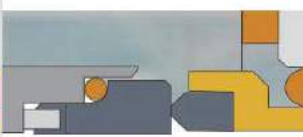
- 1 SiC (Silicon carbide) is adopted as the seal face. It has an excellent abrasion and chemical resistance which extend its service life.
- 2 It is particularly suitable for difficult sealing fluid such as "highly viscous and coagulable fluid".
- 3 Due to its reduced heat generation and its excellent heat dissipation performance, depending on the conditions, it can be used without flushing.
- 4 It is also characterized by low energy loss due to low sliding resistance.

IDEAL FOR HIGH VISCOSITY AND COAGULATING FLUID		REDUCED SLIDING HEAT GENERATION EXCELLENT COOLING PERFORMANCE	
			
Standard Mechanical Seal Bite of high viscosity liquid creates coagulum on the seal face which causes opening of the sealing surface and increases the amount of leakage.	Knife edge seal High surface pressure, due to narrow face, prevents biting of high viscosity liquid and removes coagulates. Therefore, sealing surface opening is less likely to occur which guarantees high sealing performance.	Standard Mechanical Seal An important seal face's surface generate a large amount of heat. If the cooling is insufficient, this may cause lubrication film breakage and seizure.	Knife edge seal Because the seal face is narrow, the amount of heat generation decreases. Also, it has a large heat dissipation area and excellent cooling performance on the seal end face.

※This technology does not apply to GABE 5

HIGHLY RESISTANT SLURRY TECHNOLOGY

In addition to the versatile advantage of the knife edge seal, the GXKEM type is equipped with a new mechanism "Shield O ring". Cassette seal can also be applied to services under high slurry concentration.

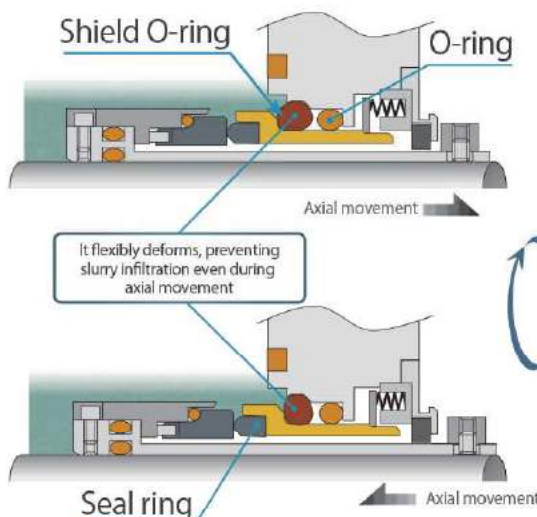

Mechanical seal for slurry is needed to solve following technical problems simultaneously.
 "Measures to prevent adhesion of fine particles to the O-ring" and
 "securing followability of the seal ring."

↓

"Shield O ring" of GXKEM type is made of special soft rubber. Its flexibility deforms freely by itself, ensuring followability of the seal ring and preventing entry of fine particles into the working O-ring.

※ Equipped with GXKEM type

Structure, Dimensions

GAKEM

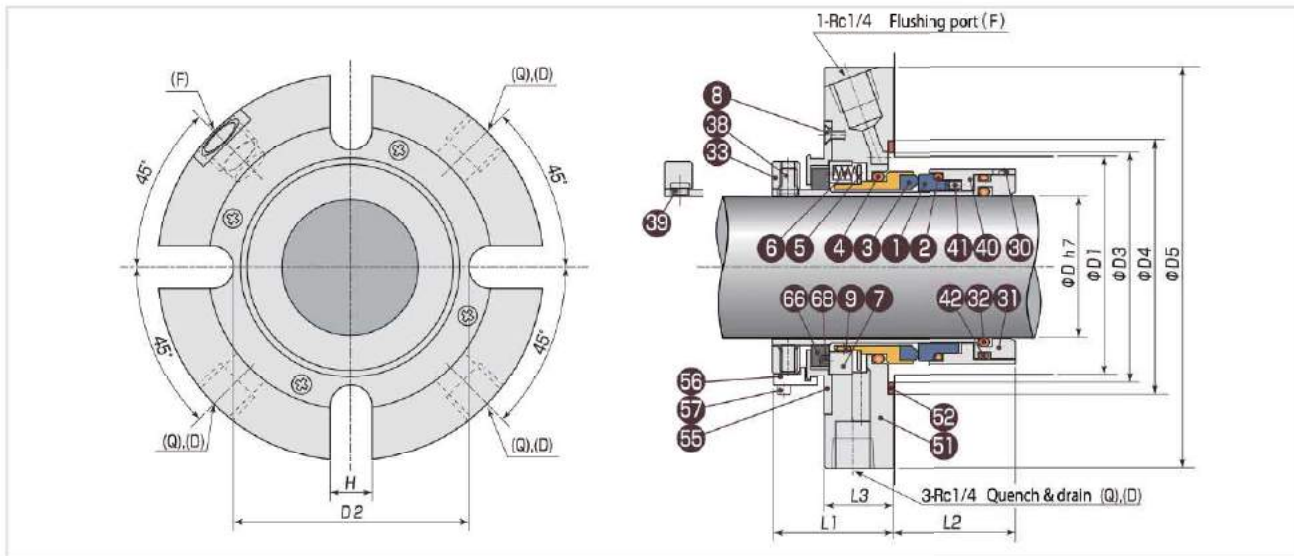

Max. pressure: 1.0 MPaG
 Velocity: ~20 m/s
 Operating temperature: -20~+150°C^{※1,※2}
 Slurry concentration: max 10wt%^{※3}

※1: Refer to the table below for applicable temperature range depending on O ring material.

※2: There is a separate [maximum boiling point of fluid -20°C] for maximum operating temperature. For higher temperature, please apply with a flushing cooler or external flushing.

※3: This value is a reference value based on experiment. Depending on the properties of the slurry, the indicated value may not be satisfied. Depending on the conditions, quenching may be required.

Material	Temperature inside the stuffing box (°C)
NBR	-20~60
EPDM	-20~100
FKM	0~150
Silicon rubber	0~150

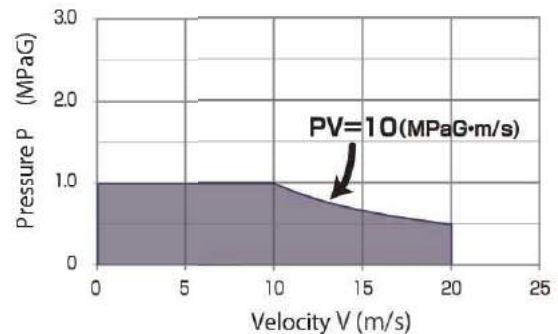

Nominal diameter	D (Shaft diameter)	D1 (min)	D1 (max)	D2	D3	D4	D5	L1	L2	L3	H
020	20	36	48	56	46	54	98	35	35	21	12
025	25	41	53	61	51	59	105	35	35	21	12
028	28	44	56	64	54	62	108	35	35	21	12
030	30	46	58	66	56	64	108	35	35	21	12
032	32	48	60	68	58	66	115	35	35	21	14
035	35	51	63	71	61	69	115	35	35	21	14
038	38	57	66	76	66	74	125	38	39	22	14
040	40	59	68	78	68	76	125	38	39	22	14
042	42	61	70	80	70	78	128	38	39	22	14
045	45	64	73	83	73	81	128	38	39	22	14
048	48	67	76	86	76	84	135	38	39	22	16
050	50	69	78	88	78	86	135	38	39	22	18
055	55	74	83	93	83	91	158	38	39	22	18
060	60	79	88	98	88	96	164	38	39	22	18
065	65	87	94	108	94	105	168	43	43	24	18
070	70	92	99	113	99	110	178	43	43	24	18
075	75	99	108	122	105	119	198	45	43	24	22
080	80	105	113	128	110	124	198	45	43	24	22
085	85	110	118	133	115	129	208	45	43	24	22
090	90	115	123	138	120	134	208	45	43	24	22
095	95	120	128	143	125	139	218	45	43	24	22
100	100	125	133	148	130	144	218	45	43	24	22

No.	Part	Material	Qty
1	Rotating ring	SIC	1
2	O ring	FKM	1
3	Seal ring	SIC&Titanium	1
4	O-ring	FKM	1
5	Plate	304 or eq.	1
6	Spring	316 or eq.	1s
7	Spring retainer	304 or eq.	1
8	Bolt	304 or eq.	4
9	Pin	304 or eq.	2
30	Pin	316 or eq.	1
31	Sleeve	316 or eq.	1
32	O-ring	FKM	1
33	Stopper ring	304 or eq.	1
38	Set screw	316 or eq.	4
39	Pin	304 or eq.	2
40	Drive ring	316 or eq.	1
41	Pin	304 or eq.	1
42	O-ring	FKM	1
51	Flange	316 or eq.	1
52	Gasket	FKM	1
55	Adapter	304 or eq.	1
56	Set plate	Carbon steel	3
57	Cap screw	304 or eq.	3
66	Throttle bush	Carbon	1
68	Pin	304 or eq.	1

● The above material is represented by GAKEM-KF 022 type as a typical example.
 ● In the above table, the O ring material is FKM, but you can choose from other EPDM, silicone rubber, NBR. (Specifications depend on the material)

and Spec.

GABE5

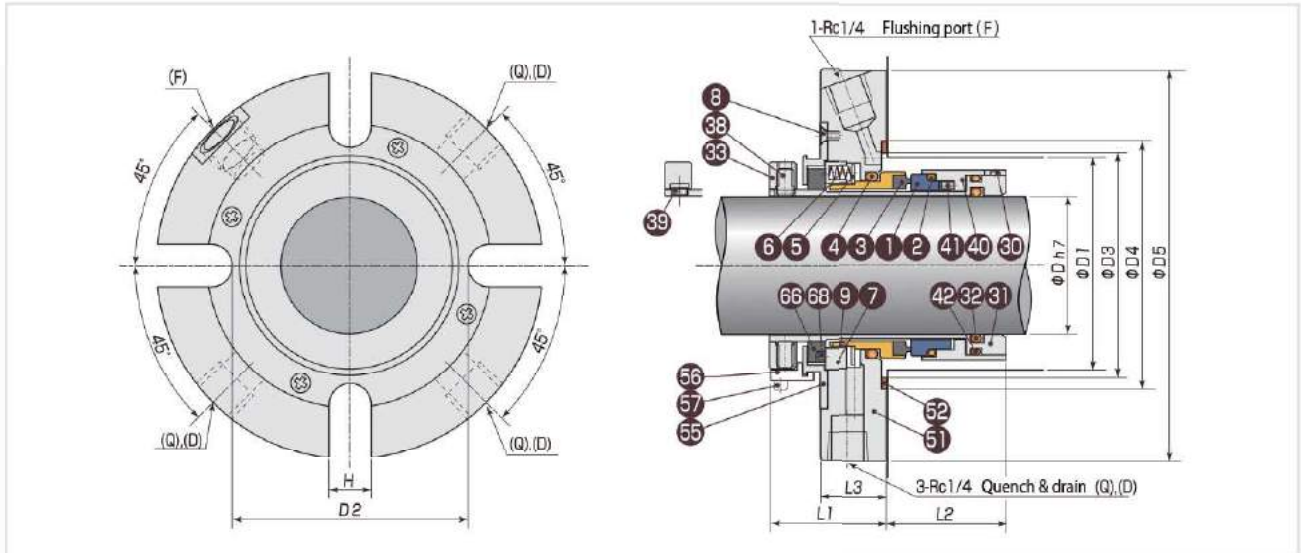

Max. pressure: 2.5 MPaG
 Velocity: ~20 m/s
 Operating temperature: -20~+150°C^{※1,※2}

※1: Refer to the table below for applicable temperature range depending on O-ring material.

※2: There is a limitation [maximum boiling point of fluid -20°C] for maximum operating temperature. For higher temperature, please apply with a flushing cooler or external flushing.

Material	Temperature inside the stuffing box(°C)
NBR	-20~60
EPDM	-20~100
FKM	0~150
Silicon rubber	0~150

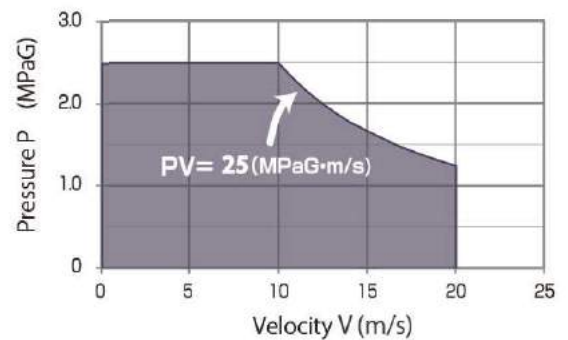

Nominal diameter	D (Shaft diameter)	D1 (min)	D1 (max)	D2	D3	D4	D5	L1	L2	L3	H
020	20	36	48	56	46	54	98	35	35	21	12
025	25	41	53	61	51	59	105	35	35	21	12
028	28	44	56	64	54	62	108	35	35	21	12
030	30	46	58	66	56	64	108	35	35	21	12
032	32	48	60	68	58	66	115	35	35	21	14
035	35	51	63	71	61	69	115	35	35	21	14
038	38	57	66	76	66	74	125	38	39	22	14
040	40	59	68	78	68	76	125	38	39	22	14
042	42	61	70	80	70	78	128	38	39	22	14
045	45	64	73	83	73	81	128	38	39	22	14
048	48	67	76	86	76	84	135	38	39	22	16
050	50	69	78	88	78	86	135	38	39	22	18
055	55	74	83	93	83	91	158	38	39	22	18
060	60	79	88	98	88	96	164	38	39	22	18
065	65	87	94	108	94	105	168	43	43	24	18
070	70	92	99	113	99	110	178	43	43	24	18
075	75	99	108	122	105	119	198	45	43	24	22
080	80	105	113	128	110	124	198	45	43	24	22
085	85	110	118	133	115	129	208	45	43	24	22
090	90	115	123	138	120	134	208	45	43	24	22
095	95	120	128	143	125	139	218	45	43	24	22
100	100	125	133	148	130	144	218	45	43	24	22

No.	Part	Material	Qty
1	Rotating ring	SiC	1
2	O-ring	FKM	1
3	Seal ring	SiC&Titanium	1
4	O-ring	FKM	1
5	Plate	304 or eq.	1
6	Spring	316 or eq.	1s
7	Spring retainer	304 or eq.	1
8	Bolt	304 or eq.	4
9	Pin	304 or eq.	2
30	Pin	316 or eq.	1
31	Sleeve	316 or eq.	1
32	O-ring	FKM	1
33	Stopper ring	304 or eq.	1
38	Set screw	316 or eq.	4
39	Pin	304 or eq.	2
40	Drive ring	316 or eq.	1
41	Pin	304 or eq.	1
42	O-ring	FKM	1
51	Flange	316 or eq.	1
52	Gasket	FKM	1
55	Adapter	304 or eq.	1
56	Set plate	Carbon steel	3
57	Cap screw	304 or eq.	3
66	Throttle bush	Carbon	1
68	Pin	304 or eq.	1

* The above material is represented by GABE5-KF022 type as a typical example.
 * In the above table, the O ring material is FKM, but you can choose from other EPDM, silicone rubber, NBR.
 (Specifications depend on the material)

Structure, Dimensions

GXKEM

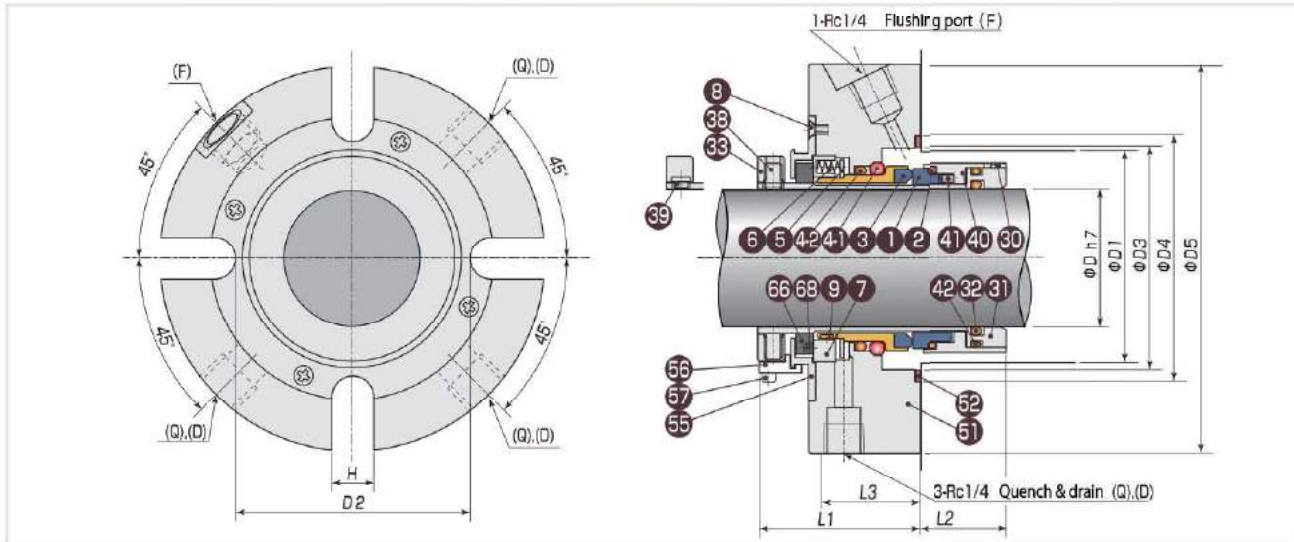

Max. working pressure: 1.0 MPaG
 Velocity: ~10 m/s
 Operating temperature limit: -20~+150°C^{※1,※2}
 Slurry concentration: max 30wt%^{※3}

※1: Refer to the table below for applicable temperature range depending on O ring material.

※2: There is a separate [maximum boiling point of fluid -40°C] for maximum operating temperature. For higher temperature, please apply with a flushing cooler.

※3: This value is a reference value based on experiment. Depending on the properties of the slurry, the indicated value may not be satisfied. Depending on the conditions, quenching may be required.

Material	Temperature inside the stuffing box (°C)
NBR	-20~60
EPDM	-20~100
FKM	0~150
Silicon rubber	0~150

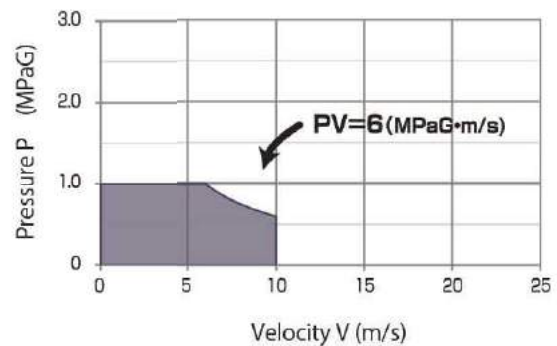

Nominal diameter	D Shaft Diameter	D1 (min)	D1 (max)	D2	D3	D4	D5	L1	L2	L3	H
020	20	36	48	56	46	54	98	49	25	35	12
025	25	41	53	61	51	59	105	49	25	35	12
028	28	44	56	64	54	62	108	49	25	35	12
030	30	46	58	66	56	64	108	49	25	35	12
032	32	48	60	68	58	66	115	49	25	35	14
035	35	51	63	71	61	69	115	49	25	35	14
038	38	57	66	76	66	74	125	53	28	37	14
040	40	59	68	78	68	76	125	53	28	37	14
042	42	61	70	80	70	78	128	53	28	37	14
045	45	64	73	83	73	81	128	53	28	37	14
048	48	67	76	86	76	84	135	53	28	37	16
050	50	69	78	88	78	86	135	53	28	37	18
055	55	74	83	93	83	91	158	53	28	37	18
060	60	79	88	98	88	96	164	53	28	37	18

No.	Part	Material	Qty
1	Rotating ring	SiC	1
2	O-ring	NBR	1
3	Seal ring	SiC&Titanium	1
4-1	Shield O-ring	NBR	1
4-2	O-ring	NBR	1
5	Blade	304 or eq.	1
6	Spring	316 or eq.	1s
7	Spring retainer	304 or eq.	1
8	Bolt	304 or eq.	4
9	Pin	304 or eq.	2
30	Pin	316 or eq.	1
31	Sleeve	316 or eq.	1
32	O-ring	NBR	1
33	Stopper ring	304 or eq.	1
38	Set screw	316 or eq.	4
39	Pin	304 or eq.	2
40	Drive ring	316 or eq.	1
41	Pin	304 or eq.	1
42	O-ring	NBR	1
51	Flange	316 or eq.	1
52	Gasket	NBR	1
55	Adapter	304 or eq.	1
56	Set plate	Carbon steel	3
57	Cap screw	304 or eq.	3
66	Throttle bush	Carbon	1
68	Pin	304 or eq.	1

* The above material is represented by GXKEM-TN000 type as a typical example.
 * In the above table, the O-ring material is NBR, but you can choose from other EPDM, silicone rubber, FKM (Specifications depend on the material)

and Spec.

Cassette Tandem Seal

FCURO-JF044×GAKEM-TF044

※ Cassette seal / Illustrates tandem seals for GAKEM type

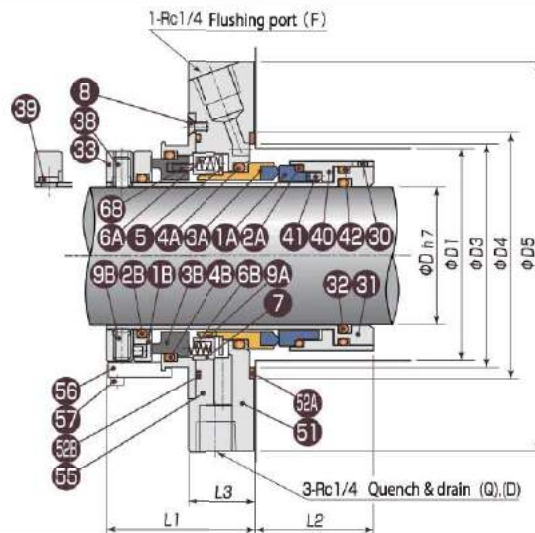
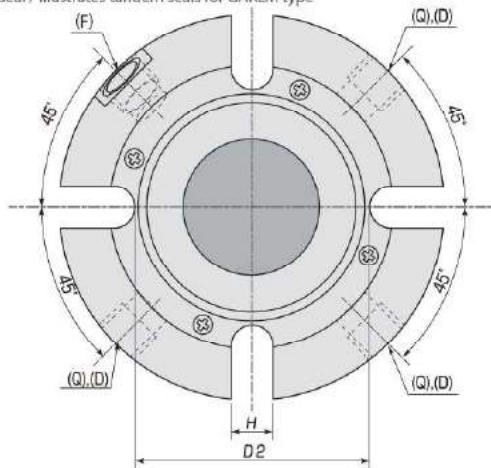

Max. pressure: 1.0 MPaG

Velocity: ~20 m/s

Operating temperature: -20~+150°C^{※1,※2}

Slurry concentration: max 10wt%^{※3}

※1: Refer to the table below for applicable temperature range depending on O ring material.

※2: There is a separate [maximum boiling point of fluid -20°C] for maximum operating temperature. For higher temperature, please apply with a flushing cooler.

※3: This value is a reference value based on experiment. Depending on the properties of the slurry, the indicated value may not be satisfied. Depending on the conditions, quenching may be required.

Material	Temperature inside the stuffing box (°C)
NBR	-20~60
EPDM	-20~100
FKM	0~150
Silicon rubber	0~150

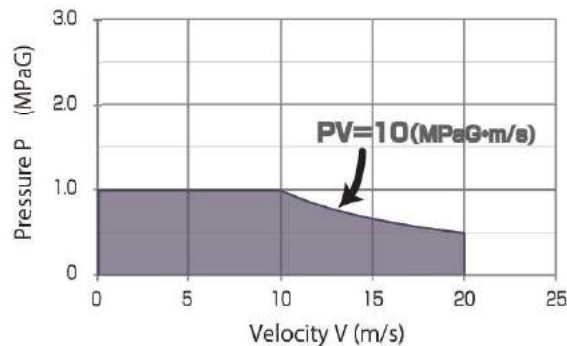

Nominal diameter	D (Shaft diameter)	D1 (min)	D1 (max)	D2	D3	D4	D5	L1	L2	L3	H
020	20	36	48	56	46	54	98	45	35	21	12
025	25	41	53	61	51	59	105	45	35	21	12
028	28	44	56	64	54	62	108	45	35	21	12
030	30	46	58	66	56	64	108	45	35	21	12
032	32	48	60	68	58	66	115	45	35	21	14
035	35	51	63	71	61	69	115	45	35	21	14
038	38	57	66	76	66	74	125	51	39	22	14
040	40	59	68	78	68	76	125	51	39	22	14
042	42	61	70	80	70	78	128	51	39	22	14
045	45	64	73	83	73	81	128	51	39	22	14
048	48	67	76	86	76	84	135	51	39	22	16
050	50	69	78	88	78	86	135	51	39	22	18
055	55	74	83	93	83	91	158	51	39	22	18
060	60	79	88	98	88	96	164	51	39	22	18
065	65	87	94	108	94	105	168	57	43	24	18
070	70	92	99	113	99	110	178	57	43	24	18
075	75	99	108	122	105	119	198	60	43	24	22
080	80	105	113	128	110	124	198	60	43	24	22

No.	Part	Material	Qty
1A	Rotating ring	SiC	1
2A	O-ring	FKM	1
3A	Seal ring	SiC/Titanium	1
4A	O-ring	FKM	1
5	Plate	304 or eq.	1
6A	Spring	316 or eq.	1s
7	Spring retainer	304 or eq.	1
8	Bolt	304 or eq.	4
9A	Pin	304 or eq.	2
1B	Rotating ring	316 or eq./ceramic	1
2B	O-ring	FKM	1
3B	Seal ring	Carbon	1
4B	O-ring	FKM	1
6B	Spring	316 or eq.	1s
9B	Pin	316 or eq.	1
30	Pin	316 or eq.	1
31	Sleeve	316 or eq.	1
32	O-ring	FKM	1
33	Stopper ring	304 or eq.	1
38	Set screw	316 or eq.	4
39	Pin	304 or eq.	2
40	Drive ring	316 or eq.	1
41	Pin	304 or eq.	1
42	O-ring	FKM	1
51	Flange	316 or eq.	1
52A	Gasket	FKM	1
52B	O-ring	FKM	1
55	Adapter	304 or eq.	1
56	Set plate	304 or eq.	3
57	Cap screw	304 or eq.	3
68	Pin	304 or eq.	2



Follow the instructions, before installation and operation, for your safety.

*Specifications and dimensions are subject to change without prior notice.

*The data on this catalogue are solely for your reference and are not to be construed as constituting a warranty.

Pillar Cassette Seal® is registered trademark of Nippon Pillar Packing Co., Ltd.

NIPPON PILLAR PACKING CO., LTD.

7-1, Shinmachi 1-chome
Nishi-ku, Osaka, 550-0013 Japan
TEL +81 6 7166 8229
FAX +81 6 7166 8513
(URL) <http://www.pillar.co.jp>

DRAFT

DISTRIBUTED BY

Pillar Casette seal® type **GAKQM**

Static cartridge-type seal solve gland-packing-related issues

Quick and easy installation

Features

- ▶ **High reliable static mechanical seal**
 - Less susceptible to imprecision on the equipment
 - Be capable of maintaining long-term stability
- ▶ **Cartridge types**
 - Allows for easy installation and replacement
 - No need to measure the setting position or make adjustments after installation
- ▶ **End faces made of SiC vs SiC**
 - The use of SiC having extremely high degree of hardness allows for use with liquid containing solid particulates
- ▶ **ISO- and DIN- standard compatible**
 - Installable on ISO and DIN standard pumps

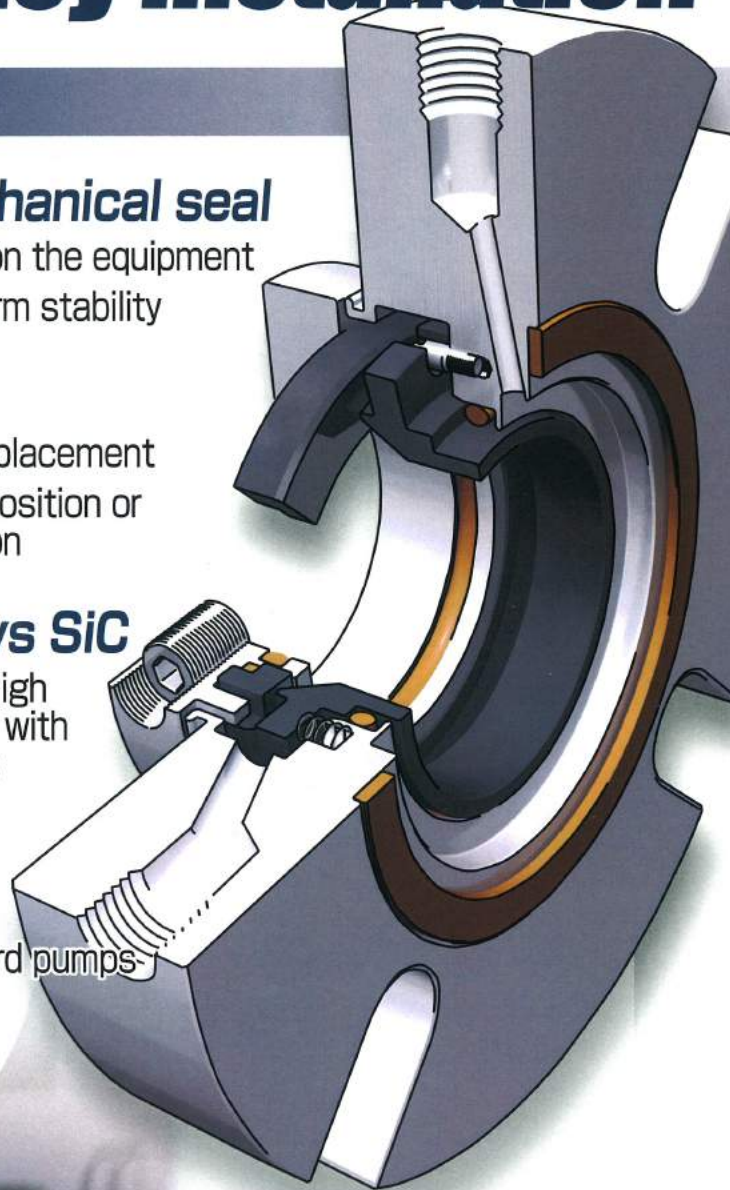

Sealing face made of SiC vs SiC

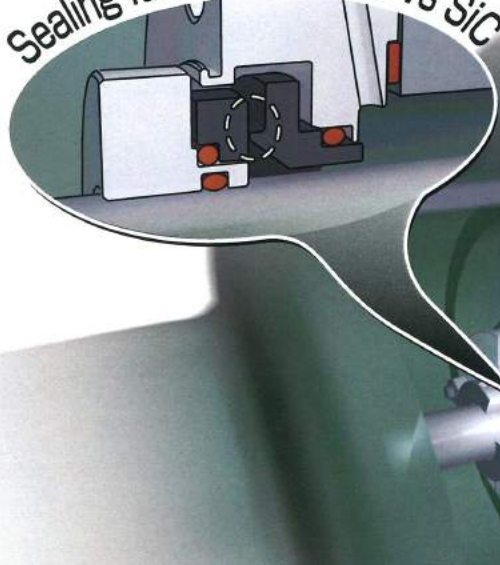

Static mechanical seal

Allows for the use of the packing tap bolts that are currently in use

Slim & Compact design

Structure and dimensions

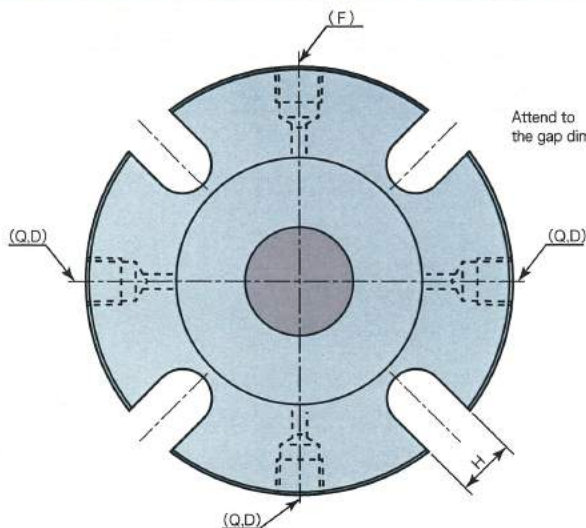

Attend to the gap dimension with the gland-bolt.

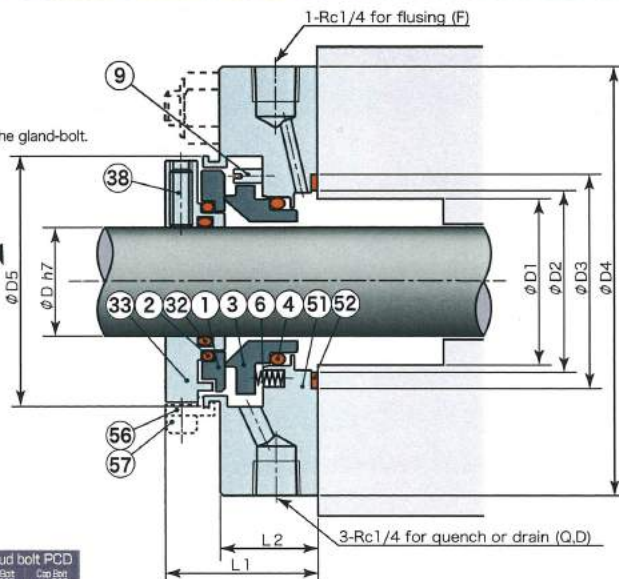

D (shaft dia.)	D1 (min.)	D1 (max.)	D2	D3	D4	D5	L1	L2	H	Reference stud bolt Box set	Hex. Bolt min. PCD	Cap Bolt min. PCD
020	36	48	46	54	98	52	35	21	12	4-M10	74	70
025	41	53	51	59	105	57	35	21	12	4-M10	79	75
028	44	56	54	62	108	60	35	21	12	4-M10	82	78
030	46	58	56	64	108	62	35	21	12	4-M10	84	80
032	48	60	58	66	115	64	35	21	14	4-M12	88	84
035	51	63	61	69	115	67	35	21	14	4-M12	91	87
038	57	66	66	74	125	72	38	24	14	4-M12	96	92
040	59	68	68	76	125	74	38	24	14	4-M12	98	94
042	61	70	70	78	128	76	38	24	14	4-M12	100	96
045	64	73	73	81	128	80	38	24	14	4-M12	104	100
048	67	76	76	84	135	82	38	24	16	4-M14	110	105
050	69	78	78	86	135	84	38	24	18	4-M16	114	110
055	74	83	83	91	158	90	38	24	18	4-M16	120	116
060	79	88	88	96	164	94	38	24	18	4-M16	124	120
065	87	94	94	105	168	102	43	27	18	4-M16	132	128
070	92	99	99	110	178	107	43	27	18	4-M16	137	133
075	99	108	105	119	198	114	45	29	22	4-M20	151	146
080	105	113	110	124	198	119	45	29	22	4-M20	156	151
085	110	118	115	129	208	124	45	29	22	4-M20	161	156
090	115	123	120	134	208	129	45	29	22	4-M20	166	161
095	120	128	125	139	218	134	45	29	22	4-M20	171	166
100	125	133	130	144	218	139	45	29	22	4-M20	176	171

No.	Part	Material	qty
1	Rotate-ring	SiC	1
2	O-ring	FKM	1
3	Seal ring	SiC	1
4	O-ring	FKM	1
6	Spring	SUS316 or eq.	1set
9	Drive pin	SUS316 or eq.	1set
32	O-ring	FKM	1
33	Stopper ring	SUS316 or eq.	1
38	Set screw	SUS316 or eq.	1set
51	Flange	SUS316 or eq.	1
52	Gasket	Glass F, PTFE	1
56	Setting spacer	Carbon steel	1set
57	Hex. cap screw	SUS304 or eq.	1set

- O-ring and gasket can choose other rubber materials.
※Product specification changes by rubber materials.
- Plug the flushing hole (F), if not use.

Usage conditions

- Speed range : ~15 m/s
(shaft dia. rotation speed : V m/s)
- Pressure range : 0~0.8 MPaG
- Temperature range : -20~150°C
- Liquid type : Water and Oil
(max. solid particulate concentration : 5 wt%)

NOTE

- 1) Recommended flushing rate : 2~3 ℓ/min
(to maintain proper lubrication on the sealing face)
- 2) If the temperature of the fluid is less than -40 °C of its boiling point, can be used without flushing and quenching.
※Please confirm with us, it depend on operating condition, (liquid type, pressure, etc.)
In case of the more high-temperature, please do the quenching and external-flushing, and equip cooler.
- 3) Depending on the material of the O-ring or gasket, application conditions will be changed. (Please see right table)

PV range

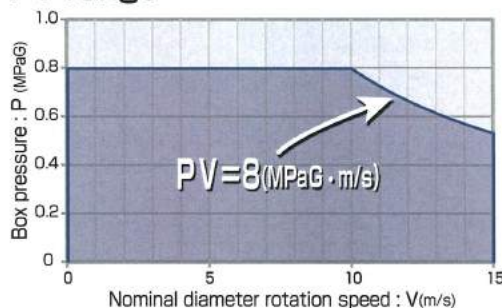

Material	Stuffing box temperature (°C)
NBR	-20~60
EPDM	-20~100
FKM	0~150
Perfluoro elastomer	0~150

PILLAR NIPPON PILLAR PACKING CO., LTD.

Head Office: 11-48, Nonakaminami 2 chome, Yodogawaku, Osaka, 532-0022 Japan.

Tel: 81-(0)6-6305-1941 Fax: 81-(0)6-6305-0606

- *Specifications and dimensions are subject to change without prior notice.
- *The data on this leaflet are solely for your reference and are not to be construed as constituting a warranty.
- *Pillar Cassette Seal® is registered trademark of NIPPON PILLAR CO., LTD.

URL <http://www.pillar.co.jp/> mail sales@pillar.co.jp



caution

Flow the instructions, before instration and operation, for your safety.

PILLAR CASSETTE SEAL® SERIES



Flange **Less** Cassette Seal

solution For Easy-Handling and Low-Price

■ Easy-Handling

- 【Low Weight】 --easy maintenance
(e.g. φ35 Flangeless cassette seal : 750 gram)
- 【Cartridge Seal Complete Set】

--simple installation

- 【Knife-Edge faced SiC*】

--no Flushing operation



■ Low-Price

- 【Less Quantity of Structural Parts】

--best practice for conversion from Non-Cartridge seal

*Knife-Edge faced SiC Technology

Seal Face width (Mating face) : 0.2~0.6 mm

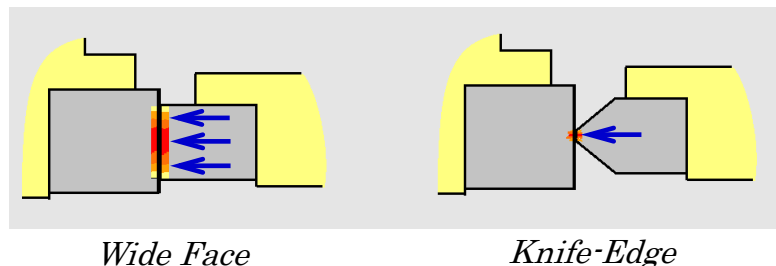

Low Heat Generation and High Heat Radiation

■ Operating Condition

Water service	:	Water, Waste water, Chemicals
Oil service	:	sp. gr. > 0.8, vis. < 200 mPa·s
Pressure	:	0 ~ 0.6 MPaG
Shaft speed	:	Max. 3600 rpm
Temperature	:	~ 60 deg C

**Ready-Made Cartridge Seal
Designed for Low - Moderate Operating Condition**

■ Easy STEP to Install

STEP1 / Check

1. Operating Condition, 2. Stuffing Box Dimension, 3. Equipment (i.e. shaft run-out/end-play etc.)

STEP2 / Machine the mounting plate

Easy to machine. just cut it from metal plate (5mm or more).

STEP3 / Install !!

■ Dimension and Standard Material

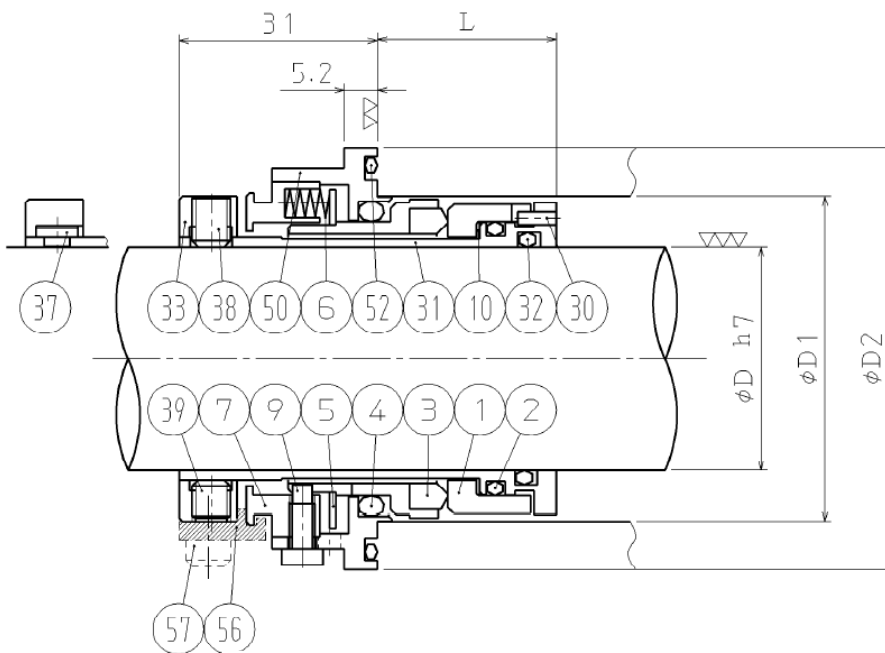

NO.	P A R T	MATERIAL	NO. REQ'D
1	ROTATING RING	SiC	1
2	O RING	FKM	1
3	SEAL RING	SiC/TITAN.	1
4	O RING	FKM	1
5	PLATE	SUS304 or eq.	1
6	SPRING	SUS316 or eq.	1S
7	SP.RETAINER	SUS304 or eq.	1
9	PIN	SUS304 or eq.	1S
10	SEAT	GLASS F.PTFE	1
30	PIN	SUS316 or eq.	1
31	SLBEVE	SUS316 or eq.	1
32	O RING	FKM	1
33	STOPPER RING	SUS304 or eq.	1
37	PIN	SUS304 or eq.	2
38	SETSCREW	SUS316 or eq.	2
39	SETSCREW	SUS316 or eq.	2
50	CASE	SUS304 or eq.	1
52	O RING	FKM	1
56	SET PLATE	CARBON STEEL	3
57	CAP BOLT	SUS304 or eq.	3

SIZE △△△	D SHAFT SIZE	D1 Min.	D2	L	REFERENCE SET BOLT PCD (min.)					
					BOLT			CAP BOLT		
					M8	M10	M12	M8	M10	M12
020	20	36	51	28	61	66	68	60	62	64
025	25	41	56	↑	66	71	73	65	67	69
028	28	44	59	↑	69	74	76	68	70	72
030	30	46	61	↑	71	76	78	70	72	74
032	32	48	63	↑	73	78	80	72	74	76
035	35	51	66	↑	76	81	83	75	77	79
038	38	57	73	31	82	87	89	82	84	86
040	40	59	75	↑	84	89	91	84	86	88
042	42	61	77	↑	86	91	93	86	88	90
045	45	64	80	↑	89	94	96	89	91	93
048	48	67	83	↑	92	97	99	92	94	96
050	50	69	85	↑	94	99	101	94	96	98
055	55	74	90	↑	99	104	106	99	101	103
060	60	79	95	↑	104	109	111	104	106	108

**Ready-Made Cartridge Seal
Designed for Low - Moderate Operating Condition**